



AC Fan

size 60 x 60 x 30mm

Airflow: 53~85m³/hr 31~50CFM
 Weight: 280g
 Noise: 25~34dBA
 Impeller: PA6 UL94V-O Reinforced Plastic
 Frame: Aluminum Alloy
 Terminals:0.5mm
 Lead Wire:AWG#24 UL 1430(Optional)
 Motor: Capacitor-Run Induction Motor
 Safety: UL.CUL.TUV.CE
 Operation Temperature:-10°C~+70°C



Model	Bearing System	Voltage VAC	Freq.	Current	Power	Speed	Sound Level	Maximum Air Flow	Maximum Static Pressure	Weight	
Part NO.	B / S / F	VAC	HZ	A	W	rpm	dBA	m3/hr	CFM	mm-H2O	g
RAH6030S1	Sleeve	220~240	50/60	0.022/0.020	5/4	2550/3100	27/28	13.8/17.5	8.1/10.3	1.7/2.8	145
RAH6030S2	Sleeve	110~125	50/60	0.035/0.042	5/4	2550/3100	27/28	13.8/17.5	8.1/10.3	1.7/2.8	145
RAH6030B1	Ball	220~240	50/60	0.022/0.020	5/4	2550/3100	27/28	13.8/17.5	8.1/10.3	1.7/2.8	145
RAH6030B2	Ball	100~125	50/60	0.035/0.042	5/4	2550/3100	27/28	13.8/17.5	8.1/10.3	1.7/2.8	145

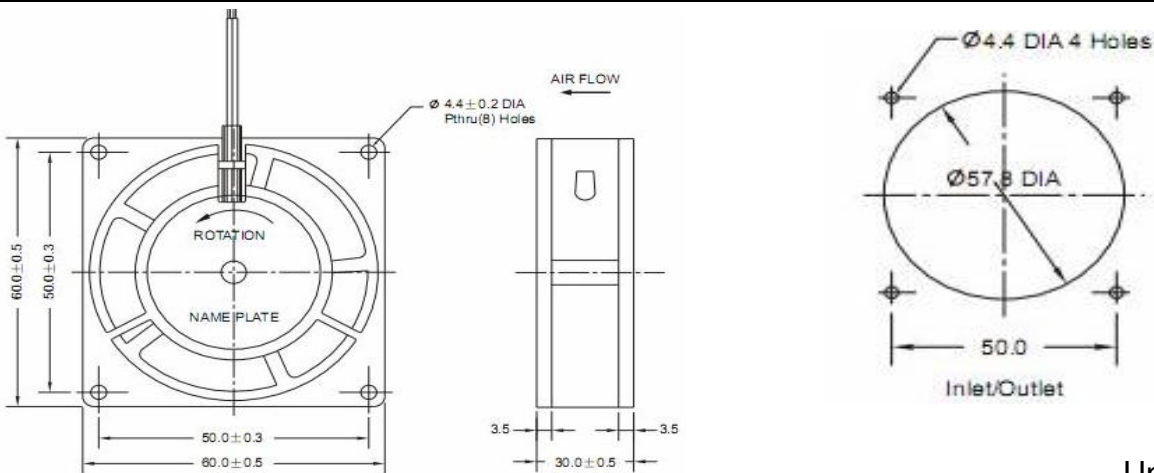

Unit: mm

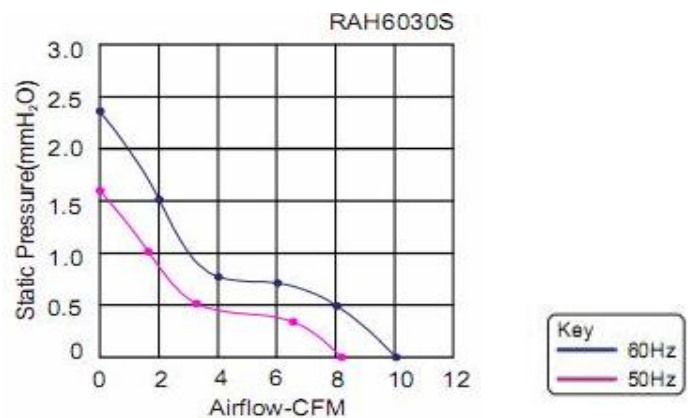
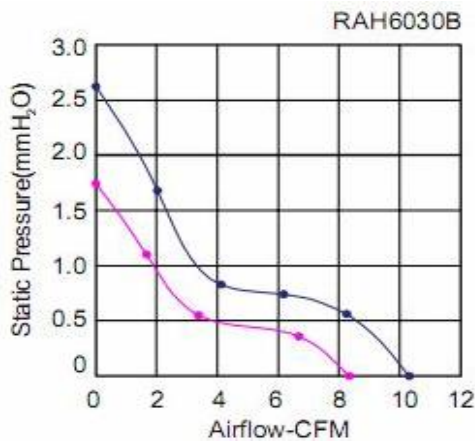

PSC Thermal Solutions